

Spring-Activated Air-Piston Vibrators

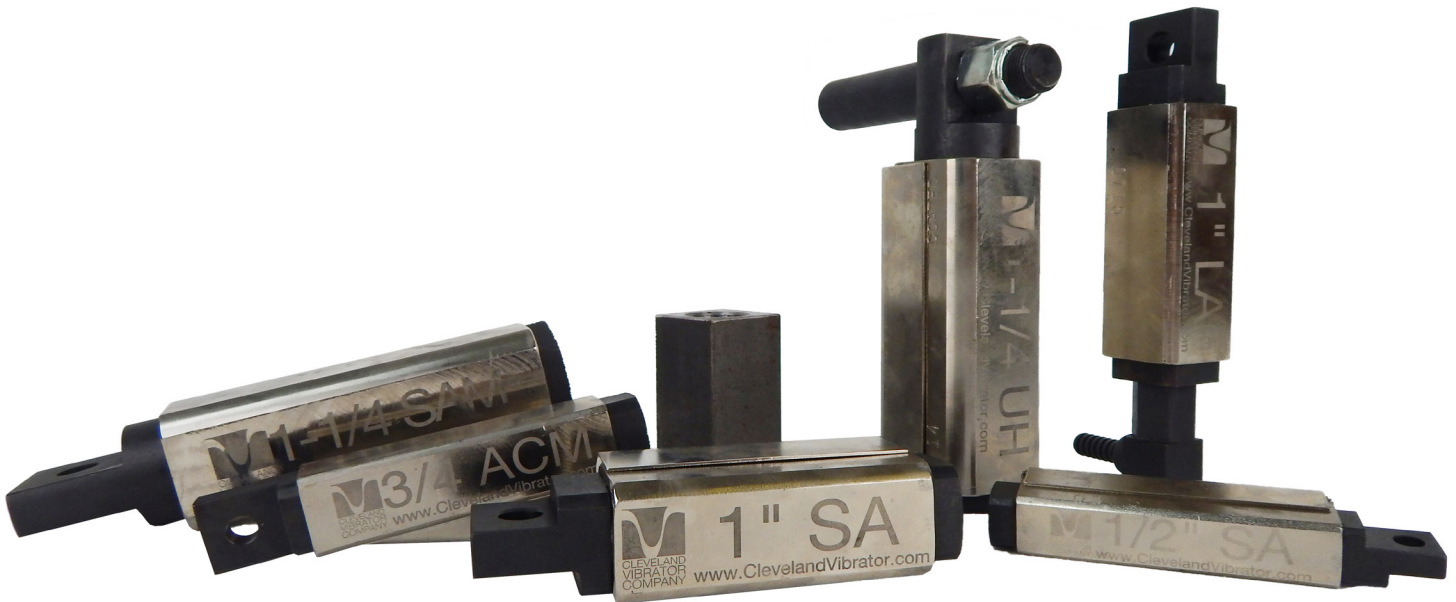

Power and Endurance You Can Hold in the Palm of Your Hand

It's linear vibration force that makes our line of Spring-Activated Air-Piston Vibrators the most powerful products of their kind. Designed for continuous duty, these products are small in size but can make a big impact on your production process. They're ideal in foundry applications for match plate, shell core machines and small bins and hoppers used in food and agriculture, pharmaceutical, medical, manufacturing, aggregate, concrete and powders.

BENEFITS INCLUDE

- Steel housing and exhaust port protection ensure a long life of continuous duty
- Air cushioning and muffler provide for reduced noise levels
- Pneumatic power allows for operation in hazardous areas
- Multiple mounting heads offer adaptability and versatility
- Mounting fasteners included to enable quick setup

Spring-Activated Air-Piston Vibrators

SPRING-ACTIVATED SA-EP

Our SA-EP line features high frequencies and adaptable mounting heads, making them highly versatile for many material flow, settling or de-airing applications. They're ideal for small bins, chutes and hoppers, feeders and parts alignment tracks as well

as molds, match plates and shell core machines. In addition to full exhaust porting protection, a variety of mounting head options is available to make installation simple for countless applications that call for a small vibrator. We also offer coated vibrators for non-lubricated applications.

PISTON DIAMETER	1/2"	5/8"	3/4"	1"	1 1/4"
	1.3 cm	1.6 cm	1.9 cm	2.5 cm	3.2 cm
A	5 3/16"	5 3/8"	5 3/8"	5 5/16"	7 7/8"
	13.2 cm	13.7 cm	13.7 cm	15.1 cm	19.4 cm
B	1"	1 1/8"	1 5/16"	1 5/8"	N/A
	2.5 cm	2.9 cm	3.3 cm	4.1 cm	
C	1 13/32"	1 17/32"	1 23/32"	2 1/32"	2 3/4"
	1.9 cm	3.9 cm	4.4 cm	5.2 cm	7 cm
D	3/4"	7/8"	1"	1 1/4"	1 5/8"
	1.9 cm	2.2 cm	2.5 cm	3.2 cm	4.1 cm
E	5/16"	1 13/32"	1 13/32"	9/16"	1 1/16"
	0.8 cm	1 cm	1 cm	1.6 cm	1.7 cm
F	1 13/16"	1"	5 3/8"	1 13/16"	1 7/16"
	2.1 cm	2.5 cm	13.7 cm	3 cm	3.7 cm
G	9/16"	3/4"	3/4"	1 5/16"	1 7/18"
	1.4 cm	1.9 cm	1.9 cm	2.4 cm	3.7 cm
H	5/16"	3/8"	3/8"	1/2"	1/2"
	0.8 cm	1 cm	1 cm	1.3 cm	1.3 cm
I	1/8"	1/4"	1/4"	1/4"	1/4"
	0.3 cm	0.6 cm	0.6 cm	0.6 cm	0.6 cm
J	1 11/32"	3/8"	7/16"	1/2"	1/2"
	0.9 c,	1 cm	1.1 cm	1.3 cm	1.3 cm
K	4 1/2"	4 1/2"	4 1/2"	4 13/16"	5 7/8"
	11.4 cm	11.4 cm	11.4 cm	12.2 cm	14.9 cm
L	5 3/4"	5 3/4"	5 3/4"	6 5/16"	9 9/8"
	14.6 cm	14.6 cm	14.6 cm	16 cm	23.2 cm
M	1/2-13nc	1/2-13nc	1/2-13nc	5/8-11nc	5/8-11nc
N	1 1/4"	1 1/4"	1 1/4"	1 1/2"	1 3/8"
	3.2 cm	3.2 cm	3.2 cm	3.8 cm	3.5 cm
O	5 1/4"	5 3/16"	5 3/8"	5 31/32"	8"
	13.3 cm	13.5 cm	13.7 cm	15.2 cm	20.3 cm
P	5 7/8"	6 1/4"	6 1/4"	7 1/16"	9 3/8"
	14.9 cm	15.9 cm	15.9 cm	17.9 cm	23.8 cm
WEIGHT	1 lb. 0.5 kg	1 1/4 lbs. 0.6 kg	1 3/4 lbs. 0.8 kg	3 1/2 lbs. 1.6 kg	6 3/4 lbs. 3.1 kg
AIR CONSUMPTION @ 60 PSIG 4.1 BAR	3.8 SCFM 108 LPM	4 SCFM 113 LPM	5 SCFM 142 LPM	5 SCFM 142 LPM	6 SCFM 170 LPM
FREQUENCY @ 60 PSIG 6.1 BAR (Vibrations Per Minute)	16,000 VPM	14,100 VPM	12,700 VPM	11,000 VPM	7,600 VPM

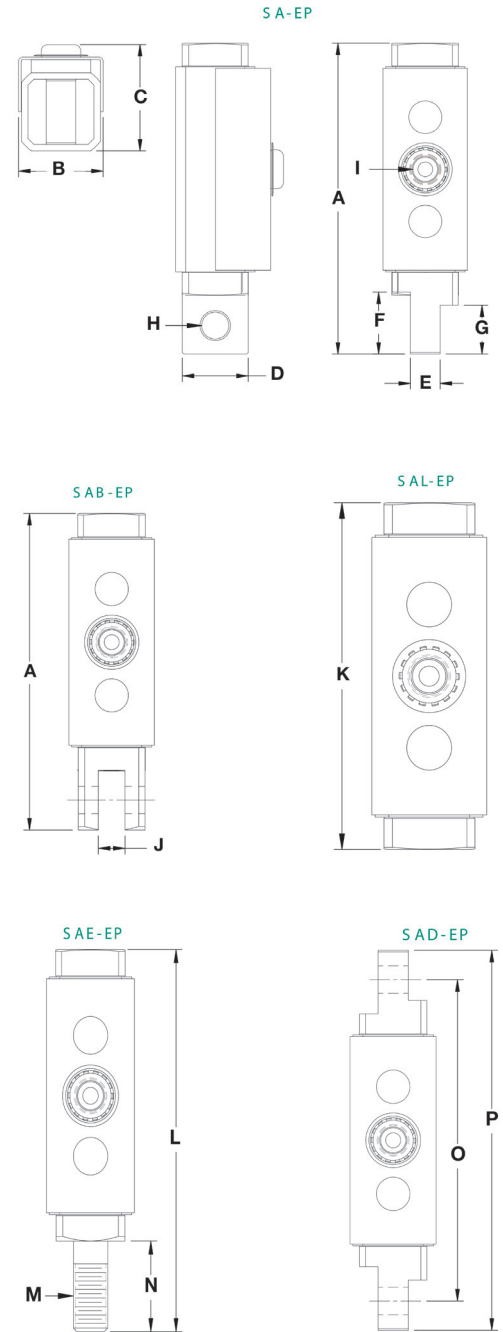

Spring-Activated Air-Piston Vibrators

ACCEPTABLE MOUNTING

Every one of our Spring-Activated Air-Piston Vibrators works with multiple mounting heads to offer versatility. That's why they're ideal for a variety of applications, even in tight places. This also makes it simple for OEMs to adapt them to existing machinery.

The 1¼" size is also available as the 1¼" UH portable mounting style, using a steel pin male piece and weld-on bracket female piece. This style is ideal for portable bins, hoppers and permanent pre-cast concrete forms. Please see product information on Portable and Railcar Vibrators in UH style.

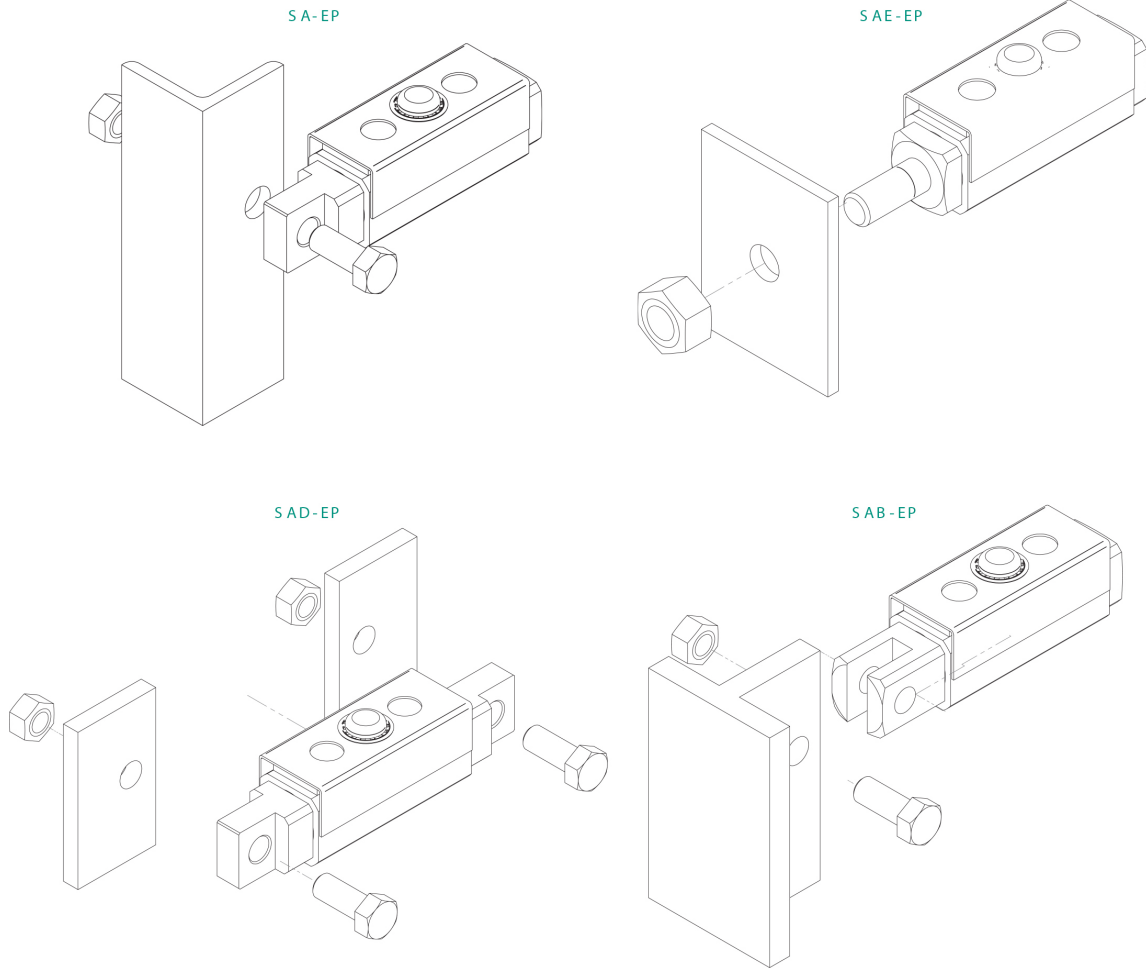

Spring-Activated Air-Piston Vibrators

SPRING-ACTIVATED SAM/ACM SERIES

Cushioned on a pad of air at each end of the stroke to ensure no metal-to-metal contact, our SAM and ACM air-cushioned piston vibrators are a quieter alternative to our SA-EP products. Standard features include a built-in exhaust manifold, which captures the exhausting air and directs it through a muffler. These products also keep material moving quickly and efficiently in small hoppers, bins, chutes, tracks and test devices.



MODEL	3/4" ACM	1" SAM	1 1/4" SAM
PISTON DIAMETER	3/4" 1.9 cm	1" 2.5 cm	1 1/4" 3.2 cm
A	5 3/4" 14.6 cm	5 7/8" 14.9 cm	7 3/4" 19.7 cm
B	N/A	2 3/4" 7 cm	2 5/8" 6.7 cm
C	1 15/16" 4.9 cm	2 1/4" 5.7 cm	2 5/8" 6.7 cm
D	1/4" 0.6 cm	1/4" 0.6 cm	1/4" 0.6 cm
E	3/8" 1 cm	1/2" 1.3 cm	1/2" 1.3 cm
F	1 13/16" 3 cm	1 1/2" 3.8 cm	2" 5.1 cm
WEIGHT	2 lbs. 0.91 kg	3 lbs. 1.36 kg	5 lbs. 2.3 kg
AIR CNSMP. @ 80 PSIG 5.4 BAR	2.8 SCFM 79.3 LPM	3.7 SCFM 105 LPM	7 SCFM 198 LPM
FREQUENCY @ 80 PSIG 5.4 BAR	3,550 VPM	3,900 VPM	3,200 VPM

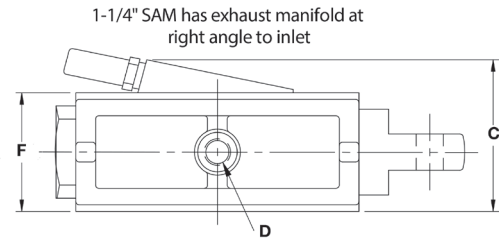
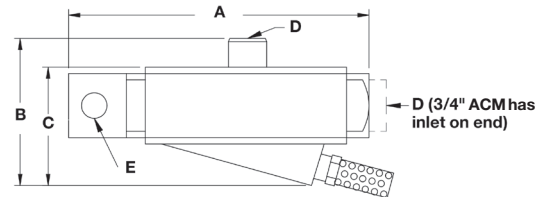

FOR MORE INFORMATION

Call: Sales at 800-221-3298

Email: sales@clevelandvibrator.com

Buy Online: www.clevelandvibrator.com



ABOUT THE
CLEVELAND
VIBRATOR
COMPANY

The Cleveland Vibrator Company has been driving innovations in materials handling since 1923. From our corporate headquarters in Cleveland, Ohio, and in partnership with HK Technologies located in Salem, Ohio, we've met the challenges of more

than 15,000 customers all around the globe in a vast array of industries. Our comprehensive product line includes air-piston, rotary electric, electromagnetic, turbine and ball vibrators, as well as a wide variety of fabricated feeders, vibratory screeners,

ultrasonic screeners, vibratory conveyers and vibratory tables used for light, medium and heavy-duty industrial applications.